

**Attached
Residential
Patio Cover
Details**

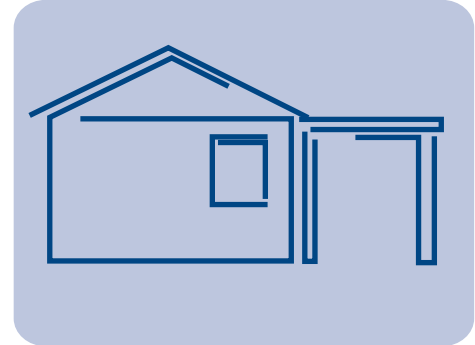

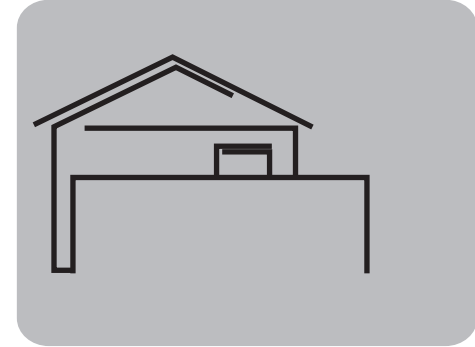

CITY OF SCOTTSDALE SUBMITTAL REQUIREMENTS FOR AN ATTACHED RESIDENTIAL PATIO COVER

This information covers the basic requirements for the construction or replacement or a residential patio cover for single-family residence. A building permit is required for any attached addition to the residence including the construction of an attached patio cover or for the repair and replacement or an existing patio cover. Any electrical that is added to an existing patio cover also requires a permit. This should not be considered as a complete list of code requirements. Inspections must be passed before the work is considered completed by the City of Scottsdale.

A. DEFINITIONS

A patio cover is a one-story structure, not exceeding 12 feet in height, attached to the existing residence and is entirely open on two or more sides. Patio covers shall be used only for recreational and outdoor living purposes.

B. LOCATION

The location of the patio cover must meet the setback requirements for your property zoning. A copy of the City of Scottsdale standard zoning requirements is included. If your property is located in a planned community development with amended standards or if you do not know your zoning please contact the Planning and Development Services Department at 480-312-7083. **NOTE:** setbacks are measured from property lines.

C. PERMIT AND PLAN REQUIREMENTS

- Plot plan-provide a plot plan (see attached example) showing the streets, property lines, lot dimensions, location of the existing house on the lot and the location of the new patio cover. Provide the setback dimensions from property lines and any existing structures that may be adjacent to the building area. You may check with the City Records Department (480-312-2356) to see if there is an existing site plan on file for your property. If one is not available, you can get a copy of your subdivision lot showing the lot dimensions and any easements that may be on your property.
- Building plans-the attached building plans are for your use. You cannot exceed the building dimensions that are shown. Provide the actual dimensions and height of the building that you intend to build and label the use.

D. INSPECTION REQUIREMENTS

You will be provided an inspection card that will list and detail the required inspections. The following list is for your information and may vary depending on what you will be including in your building.

- A miscellaneous footing inspection.
- A rough framing inspection NOTE: if you are providing electrical you will also need a rough electrical inspection.
- Wall board/drywall inspection (if being installed)
- A final inspection for framing and electrical (if applicable)

Phone Numbers:

Inspection Services	480-312-5750
Development Services- Planning and Zoning Division	480-312-7083
Automated Inspection Request Line	480-312-5796

ABBREVIATIONS:

W/N=WITHIN

O.C=ONCENTER

PRESS.=PRESSURE TREATED

P.U.E.=PUBLIC UTILITY EASEMENT

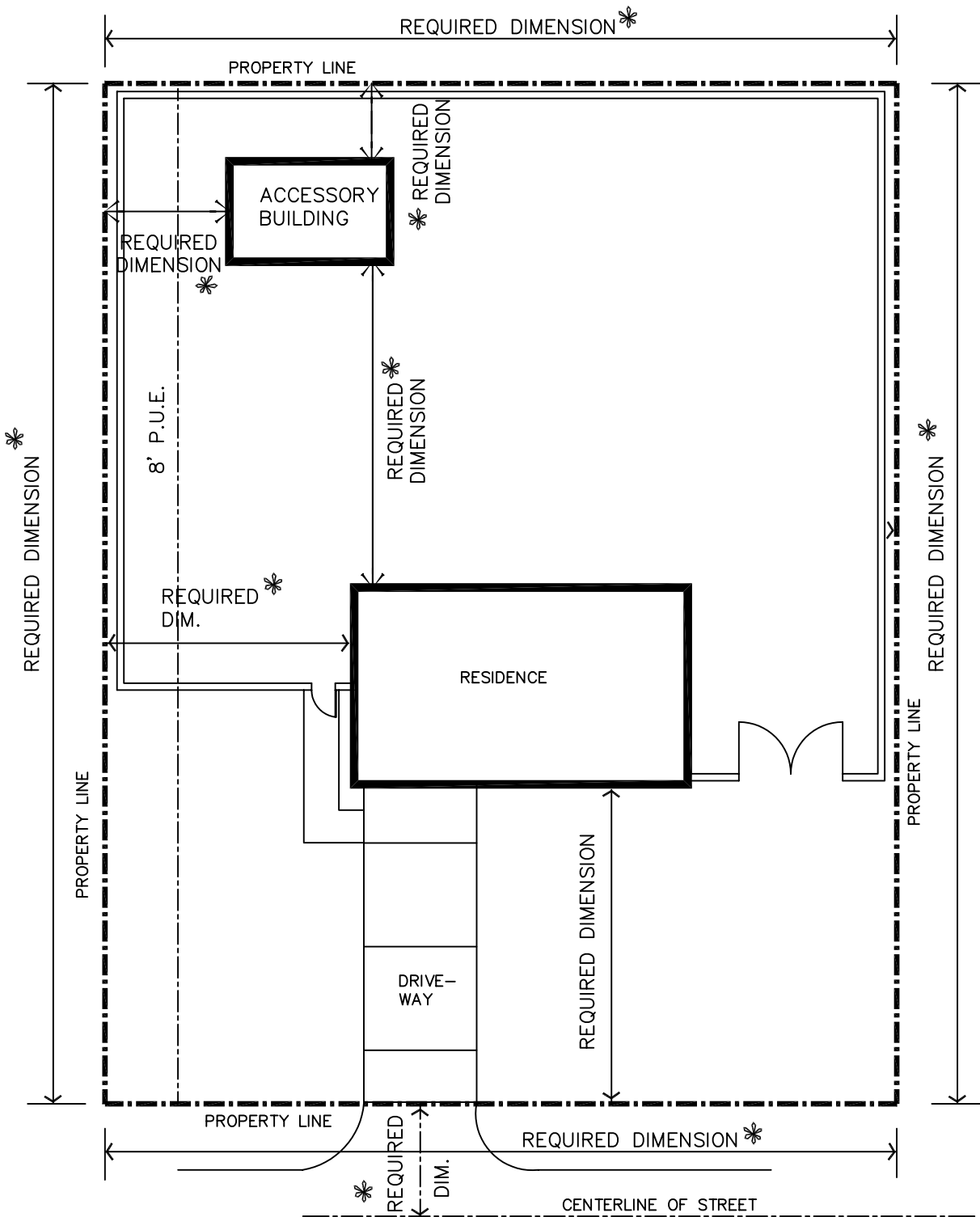

PROVIDE :
 ADDRESS AND
 ASSESSORS PARCEL
 NUMBER OF
 PROJECT

DIMENSIONS OF
 PROPERTY AND
 EASEMENTS
 AVAILABLE FROM
 RECORDS DEPT.
 DIMENSIONS FROM
 PROPERTY LINES
 AND ALL EXISTING
 STRUCTURES,
 WALLS AND
 SWIMMING POOLS

SHOW LOCATION
 AND SIZE OF ALL
 DRAINAGE
 OPENINGS
 IN BLOCK WALLS

TYPICAL SITE PLAN



FEMA BLOCK

Flood Insurance Rate Map (FIRM) Information

Community No.	Panel No.	Suffix	Date of FIRM	FIRM Zone	Base Flood Elev.	(In AO zone, give depth and velocity)
	Date					

(For Areas Under Study Or Preliminary F.I.R.M.)

Source of Map	Date of Map	Flood Zone	Base Flood Elevation	(In AO Zone, give depth and velocity. No habitable floors are permitted below lowest floor elevation)
---------------	-------------	------------	----------------------	---

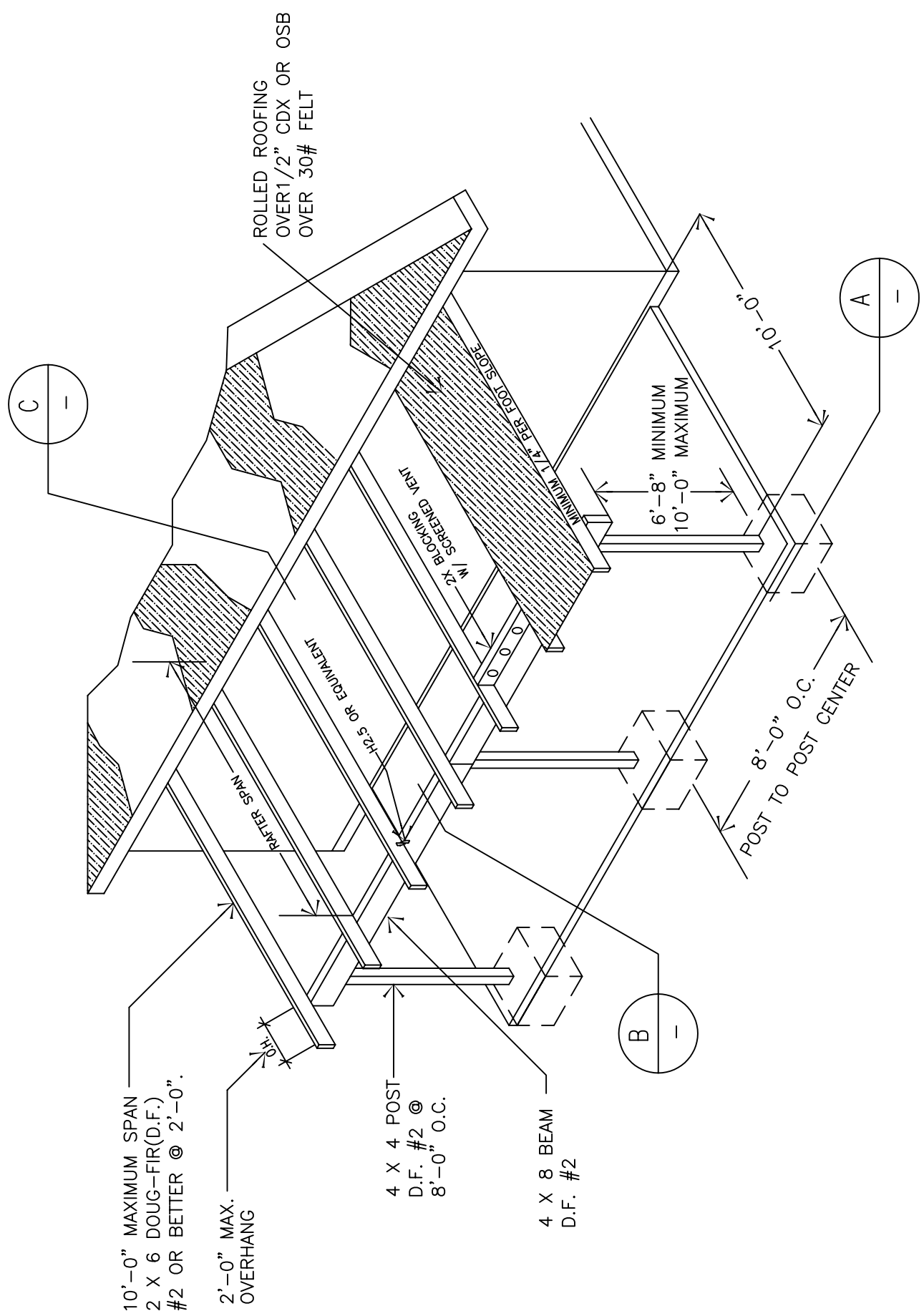

PATIO COVER

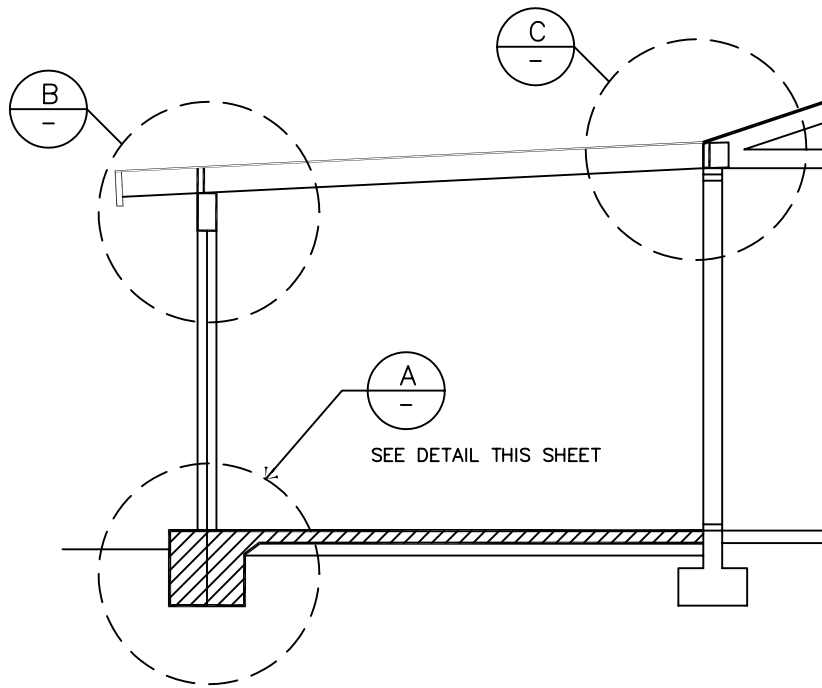

PATIO KEY SECTION

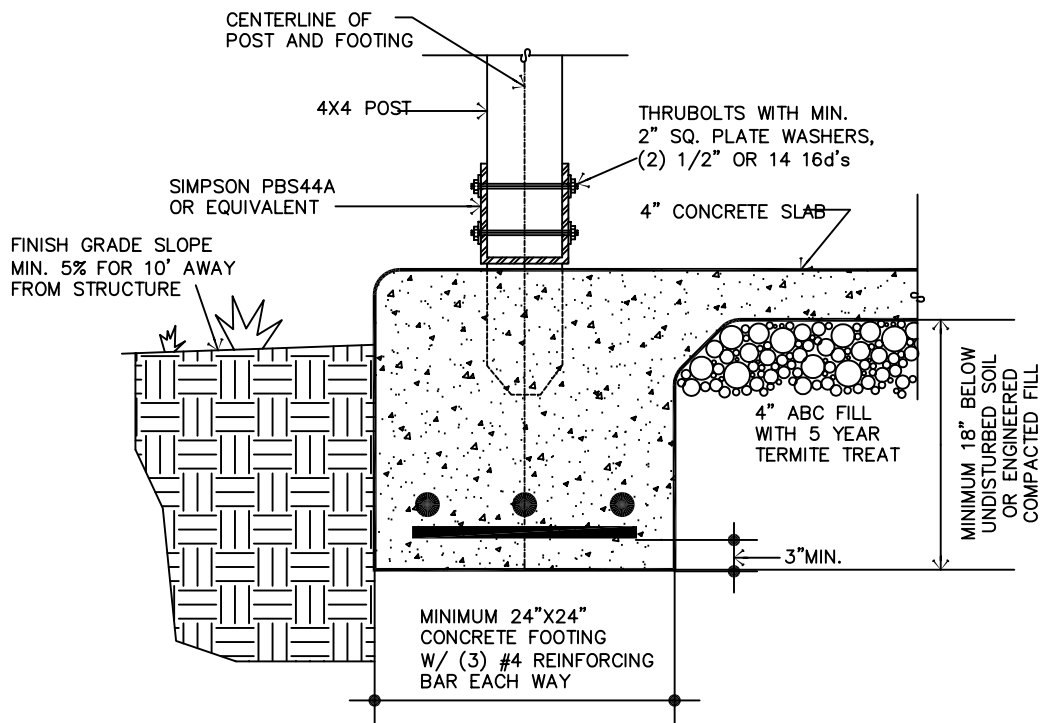

A
-
PATIO POST FOOTING

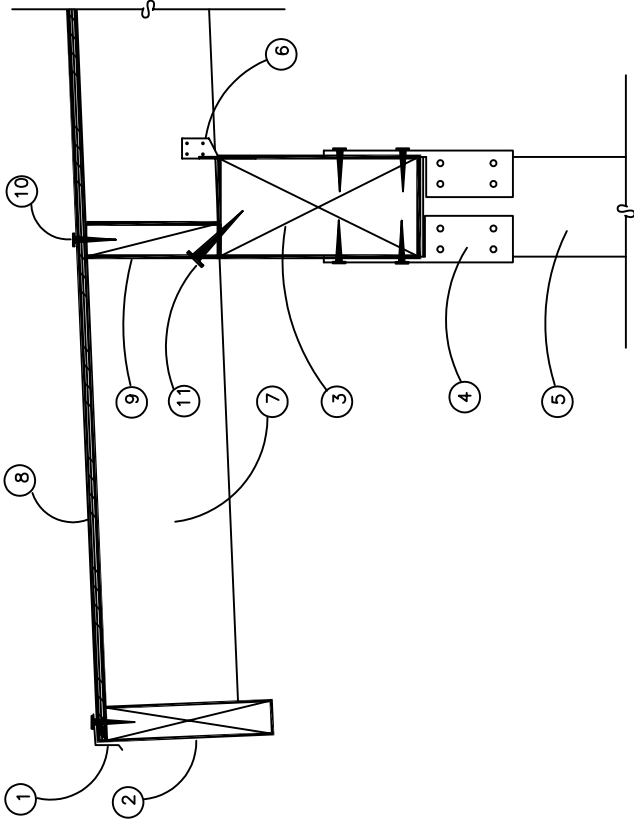

- ① GALVANIZED IRON DRIP EDGE
- ② 2 X 8 FASCIA
- ③ PATIO BEAM, SEE PLAN FOR SIZE
- ④ PC44 OR EQUIVALENT
- ⑤ POST, SEE PLAN FOR SIZE
- ⑥ H2.5 @ EA. ROOF RAFTER
- ⑦ PATIO RAFTER, SEE PLAN FOR SIZE & SPACING
- ⑧ 1/2" CDX PLYWOOD SHEATHING
- ⑨ 2 x SOLID BLOCKING
- ⑩ EDGE NAILING 8d @ 6" O/C MIN.
- ⑪ 3-16d/BAY TOENAILING TO TOP PLATE

⊖
B
-
PATIO BEAM
CONNECTION

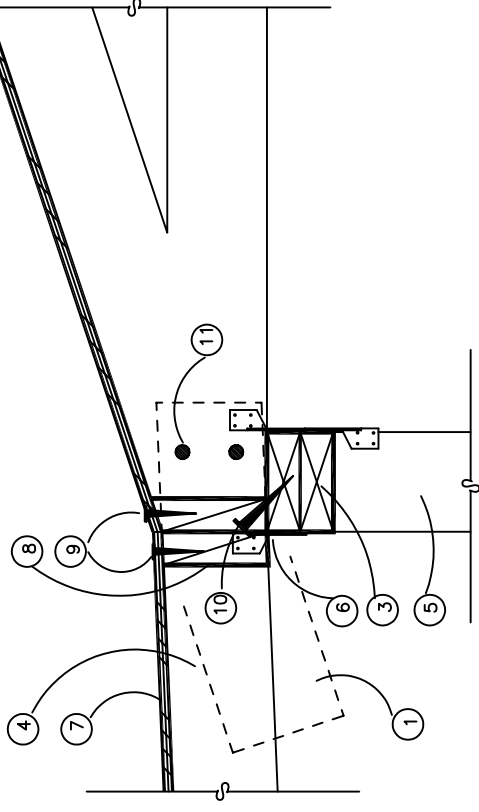

- ① CUT OVERHANG OFF, FLUSH W/ TOP PLATE
- ② NOT USED
- ③ DOUBLE TOP PLATE
- ④ NEW JOISTS BEARING ON TOP PLATE, SEE PLAN FOR SIZE
- ⑤ EXISTING STUD WALL
- ⑥ H2.5@ EA. ROOF RAFTER
- ⑦ 1/2" CDX PLYWOOD SHEATHING
- ⑧ 2 x SOLID BLOCKING
- ⑨ EDGE NAILING 8d @ 6" O/C MIN.
- ⑩ 3-16d/BAY TOENAILING TO TOP PLATE
- ⑪ MINIMUM TWO 10d NAIL

⊖
C
-
PATIO ROOF TO
EXISTING HOUSE

**TABLE R602.3(1)
FASTENER SCHEDULE FOR STRUCTURAL MEMBERS**

DESCRIPTION OF BUILDING ELEMENTS	NUMBER AND TYPE OF FASTENER ^{a,b,c,d}	SPACING OF FASTENERS
Joist to sill or girder, toe nail	3-8d	—
1" x 6" subfloor or less to each joist, face nail	2-8d 2 staples, 1 ³ / ₄ "	— —
2" subfloor to joist or girder, blind and face nail	2-16d	—
Sole plate to joist or blocking, face nail	16d	16" o.c.
Top or sole plate to stud, end nail	2-16d	—
Stud to sole plate, toe nail	3-8d or 2-16d	—
Double studs, face nail	10d	24" o.c.
Double top plates, face nail	10d	24" o.c.
Sole plate to joist or blocking at braced wall panels	3-16d	16" o.c.
Double top plates, minimum 24-inch offset of end joints, face nail in lapped area	8-16d	—
Blocking between joists or rafters to top plate, toe nail	3-8d	—
Rim joist to top plate, toe nail	8d	6" o.c.
Top plates, laps at corners and intersections, face nail	2-10d	—
Built-up header, two pieces with 1/2" spacer	16d	16" o.c. along each edge
Continued header, two pieces	16d	16" o.c. along each edge
Ceiling joists to plate, toe nail	3-8d	—
Continuous header to stud, toe nail	4-8d	—
Ceiling joist, laps over partitions, face nail	3-10d	—
Ceiling joist to parallel rafters, face nail	3-10d	—
Rafter to plate, toe nail	2-16d	—
1" brace to each stud and plate, face nail	2-8d 2 staples, 1 ³ / ₄ "	— —
1" x 6" sheathing to each bearing, face nail	2-8d 2 staples, 1 ³ / ₄ "	— —
1" x 8" sheathing to each bearing, face nail	2-8d 3 staples, 1 ³ / ₄ "	— —
Wider than 1" x 8" sheathing to each bearing, face nail	3-8d 4 staples, 1 ³ / ₄ "	— —
Built-up corner studs	10d	24" o.c.
Built-up girders and beams, 2-inch lumber layers	10d	Nail each layer as follows: 32" o.c. at top and bottom and staggered. Two nails at ends and at each splice.
2" planks	2-16d	At each bearing
Roof rafters to ridge, valley or hip rafters: toe nail	4-16d	—
face nail	3-16d	—
Rafter ties to rafters, face	3-8d	—
Wood structural panels, subfloor, roof and wall sheathing to framing, and particleboard wall sheathing to framing		
5/16"-1/2"	6d common nail (subfloor, wall) 8d common nail (roof) ^f	12 ^g
19/32" -1"	8d common nail	12 ^g
1 1/8" -1 1/4"	10d common nail or 8d deformed nail	12

(continued)

TABLE R602.3(1)—continued
FASTENER SCHEDULE FOR STRUCTURAL MEMBERS

DESCRIPTION OF BUILDING MATERIALS	DESCRIPTION OF FASTENER ^{b,c,d,e}	SPACING OF FASTENERS	
		Edges (inches) ^f	Intermediate supports ^{g,h} (inches)
Other wall sheathing^h			
1/2" regular cellulosic fiberboardsheathing	1 1/2" galvanized roofing nail 6d common nail staple 16 ga., 1 1/2" long	3	6
1/2" structural cellulosic fiberboard sheathing	1 1/2" galvanized roofing nail 8d common nail staple 16 ga., 1 1/2" long	3	6
25/32" structural cellulosic fiberboard sheathing	1 3/4" galvanized roofing nail 8d common nail staple 16 ga., 1 3/4" long	3	6
1/2" gypsum sheathing	1 1/2" galvanized roofing nail; 6d common nail; staple galvanized, 1 1/2" long; 1 1/4" screws, Type W or S	4	8
5/8" gypsum sheathing	1 3/4" galvanized roofing nail; 8d common nail; staple galvanized, 1 5/8" long; 1 5/8" screws, Type W or S	4	8
Wood structural panels, combination subfloor underlayment to framing			
3/4" and less	6d deformed nail or 8d common nail	6	12
7/8"-1"	8d common nail or 8d deformed nail	6	12
1 1/8"-1 1/4"	10d common nail or 8d deformed nail	6	12

For SI: 1 inch = 25.4 mm, 1 foot = 304.8 mm, 1 mile per hour = 1.609 km/h.

- a. All nails are smooth-common, box or deformed shanks except where otherwise stated. Nails used for framing and sheathing connections shall have minimum average bending yield strengths as shown: 80 ksi (551 MPa) for shank diameter of 0.192 inch (20d common nail), 90 ksi (620 MPa) for shank diameters larger than 0.142 inch but not larger than 0.177 inch, and 100 ksi (689 MPa) for shank diameters of 0.142 inch or less.
- b. Staples are 16 gage wire and have a minimum 7/16-inch on diameter crown width.
- c. Nails shall be spaced at not more than 6 inches on center at all supports where spans are 48 inches or greater.
- d. Four-foot-by-8-foot or 4-foot-by-9-foot panels shall be applied vertically.
- e. Spacing of fasteners not included in this table shall be based on Table R602.3(1).
- f. For regions having basic wind speed of 110 mph or greater, 8d deformed nails shall be used for attaching plywood and wood structural panel roof sheathing to framing within minimum 48-inch distance from gable end walls, if mean roof height is more than 25 feet, up to 35 feet maximum.
- g. For regions having basic wind speed of 100 mph or less, nails for attaching wood structural panel roof sheathing to gable end wall framing shall be spaced 6 inches on center. When basic wind speed is greater than 100 mph, nails for attaching panel roof sheathing to intermediate supports shall be spaced 6 inches on center for minimum 48-inch distance from ridges, eaves and gable end walls; and 4 inches on center to gable end wall framing.
- h. Gypsum sheathing shall conform to ASTM C 79 and shall be installed in accordance with GA 253. Fiberboard sheathing shall conform to either AHA 194.1 or ASTM C 208.
- i. Spacing of fasteners on floor sheathing panel edges applies to panel edges supported by framing members and at all floor perimeters only. Spacing of fasteners on roof sheathing panel edges applies to panel edges supported by framing members and at all roof plane perimeters. Blocking of roof or floor sheathing panel edges perpendicular to the framing members shall not be required except at intersection of adjacent roof planes. Floor and roof perimeter shall be supported by framing members or solid blocking.

TABLE R602.3(2)
ALTERNATE ATTACHMENTS

NOMINAL MATERIAL THICKNESS (inches)	DESCRIPTION ^{a, b} OF FASTENER AND LENGTH (inches)	SPACING ^c OF FASTENERS	
		Edges (inches)	Intermediate supports (inches)
Wood structural panels subfloor, roof and wall sheathing to framing and particleboard wall sheathing to framing^f			
5/16	0.097 - 0.099 Nail 1 1/2	6	12
	Staple 15 ga. 1 3/8		
	Staple 16 ga. 1 3/4		
3/8	Staple 15 ga. 1 3/8	6	12
	0.097 - 0.099 Nail 1 1/2	4	10
	Staple 16 ga. 1 3/4	6	12
15/32 and 1/2	Staple 15 ga. 1 1/2	6	12
	0.097 - 0.099 Nail 1 5/8	3	6
	Staple 16 ga. 1 3/4	6	12
19/32 and 5/8	0.113 Nail 1 7/8	6	12
	Staple 15 and 16 ga. 1 5/8		
	0.097 - 0.099 Nail 1 3/4		
23/32 and 3/4	Staple 14 ga. 1 3/4	6	12
	Staple 15 ga. 1 3/4	5	10
	0.097 - 0.099 Nail 1 7/8	3	6
	Staple 16 ga. 2	4	8
1	Staple 14 ga. 2	5	10
	0.113 Nail 2 1/4, Staple 15 ga. 2	4	8
	0.097 - 0.099 Nail 2 1/8	3	6
NOMINAL MATERIAL THICKNESS (inches)	DESCRIPTION ^{a, b} OF FASTENER AND LENGTH	SPACING ^c OF FASTENERS	
		Edges (inches)	Body of panel (inches)
Floor underlayment; plywood-hardboard-particleboard^f			
Plywood			
1/4 and 5/16	1 1/4 ring or screw shank nail—minimum 12 1/2 ga. (0.099") shank diameter	3	6
	Staple 18 ga., 7/8, 3/16 crown width	2	5
11/32, 3/8, 15/32 and 1/2	1 1/4 ring or screw shank nail—minimum 12 1/2 ga. (0.099) shank diameter	6	8 ^c
19/32, 5/8, 23/32 and 3/4	1 1/2 ring or screw shank nail—minimum 12 1/2 ga. (0.099) shank diameter	6	12
	Staple 16 ga. 1 1/4	6	8
Hardboard^f			
0.200	1 1/2 long ring-grooved underlayment nail	6	6
	4d cement-coated sinker nail	6	6
	Staple 18 ga., 7/8 long (plastic coated)	3	6
Particleboard			
1/4	4d ring-grooved underlayment nail	3	6
	Staple 18 ga., 7/8 long, 3/16 crown	3	6
3/8	6d ring-grooved underlayment nail	6	10
	Staple 16 ga., 1 1/8 long, 3/8 crown	3	6
1/2, 5/8	6d ring-grooved underlayment nail	6	10
	Staple 16 ga., 1 5/8 long, 3/8 crown	3	6

For SI: 1 inch = 25.4 mm.

a. Nail is a general description and may be T-head, modified round head or round head.

b. Staples shall have a minimum crown width of 7/16-inch on diameter except as noted.

c. Nails or staples shall be spaced at not more than 6 inches on center at all supports where spans are 48 inches or greater. Nails or staples shall be spaced at not more than 12 inches on center at intermediate supports for floors.

d. Fasteners shall be placed in a grid pattern throughout the body of the panel.

e. For 5-ply panels, intermediate nails shall be spaced not more than 12 inches on center each way.

f. Hardboard underlayment shall conform to ANSI/AHA A135.4.